

Numelock II

Polyaxial Locking System

Operative Technique

Trauma Applications



Contents

	Page
1. Rationale	3
Plates	4
Material Composition	4
Locking Screws	4
Polyaxial Locking Mechanism	5
Compatibility	5
Instrumentation	5
2. Introduction	5
Cases and Trays	5
Locking Screw Instrumentation	5
Locking Screws	5
3. Indications	7
4. Contraindications	8
5. Features and Benefits	9
Features	9
Benefits	9
6. Operative Technique	10
General Principles	10
Step One – Plate Contouring and Shaft Screw Placement	10
Step Two – Pre-drilling for Locking Screw Placement	10
Step Three – Depth measurement	11
Step Four – Locking Screw Placement	11
Step Five – Final Adjustments / Transport	12
Step Six – Final Locking	12
Step Seven – Remaining Diaphyseal Screws	12
Indication Procedures	13
7. Clinical Examples	16
Ordering Information - Plates	17
Ordering Information - Locking Screws	21
Ordering Information - Instruments	20
Ordering Information - Cases and Trays	21

Special Acknowledgement:

Special acknowledgement is made to Dr. Gilbert Taglang of the Centre de Traumatologie et d'Orthopédie, Strasbourg, for sharing his technical and surgical expertise in the compilation of this Operative Technique. Dr. Taglang significantly contributed to this manual and likewise supplied all clinical X-Rays depicted herein.

This publication sets forth detailed recommended procedures for using Stryker Trauma devices and instruments. It offers guidance that you should heed, but, as with any such technical guide, each surgeon must consider the particular needs of each patient and make appropriate adjustments when and as required.

A workshop training is required prior to first surgery. See package insert (V15013 / V15034) for a complete list of potential adverse effects, contraindications, warnings and precautions.

The surgeon must discuss all relevant risks, including the finite lifetime of the device, with the patient, when necessary.

Warning:

All bone screws referenced in this document here are not approved for screw attachment or fixation to the posterior elements (pedicles) of the cervical, thoracic or lumbar spine.

Rationale

Plating for skeletal fractures in the periarticular regions of the bone has become a widely accepted treatment modality.

In recent years, the effectiveness of epiphyseal/metaphyseal fracture management has been enhanced through the introduction of anatomically shaped and axially stable locking plates.

Locking plates have become an implant category of increasing importance to trauma surgeons because they tend to impart a higher degree of stability and improved protection against primary and secondary losses of reduction when compared to conventional plates. Additionally, locking plates can be mounted with limited contact and pressure to periosteal tissue. This reduction in pressure can minimize incidence of periosteal necrosis and may help preserve vascularization to the zone of injury by minimizing the impairment to overall blood supply. The locked plate and screws constitute a stable system that dependably maintains the angular integrity and axial alignment of the extremity, while at the same time providing reliable fixation in normal and osteoporotic bone.

Plates with threaded locking screw holes that are machine drilled directly into the implant at angles predetermined by the manufacturer have become widely available in many parts of the world. These monoaxial locking plates have been met with increasing popularity among trauma surgeons because of the improved outcomes they offer in certain clinical situations compared to conventional plates.

NumelockII's polyaxial locking mechanism offers the option of adjustability in the range of screw trajectories through a broad continuum of positions in the metaphyseal zone.

The NumelockII mechanism can be optimally adjusted to meet the needs of the clinical indication. This feature allows the NumelockII plates to be correctly situated with respect to the patient's anatomy, while each individual locking screw is accurately targeted to address the configuration of the fracture.



Rationale

Plates

The Numelock II polyaxial locking system is designed to treat periarticular fractures of the upper and lower extremities, with eight plates, covering five anatomical regions (shoulder, elbow, distal radius, knee and distal tibia).

The shape, material properties and surface quality of the implants take into account the stringent demands of surgeons for high fatigue strength, optimized transfer of loading forces and a straightforward, standardized operative technique with broad applicability. For the purposes of safety, traceability and convenience, all plates are packaged sterile.

The Numelock II system features eight plates, including distal radius (volar); proximal humerus; medial distal humerus, lateral distal humerus; medial proximal tibia; lateral proximal tibia; medial distal tibia and lateral distal femur.



Material Composition

The implants are produced from 316LVM Stainless Steel. ASTM F138 and F139/ISO 5832-1 material standards provide rigid specifications that define the chemical composition, microstructural characteristics and mechanical properties of implant quality Stainless Steel. These standards ensure that 316LVM Stainless Steel, even if provided by different suppliers, is consistent and compatible. The material used for all Numelock II plates and screws meets these standards.

Locking Screws

The Numelock II locking screws are available in two diameters for metaphyseal fixation. The 4.5mm screws are for all upper extremity and medial distal tibia Numelock II plates and the 6.5mm screws are used with the remaining lower extremity Numelock II plates. All screws are packaged sterile.



Rationale

Polyaxial Locking Mechanism

Depending on the anatomical region, the epiphyseal/metaphyseal section of each plate includes three or more polyaxial locking holes, with integrated rings that accept Numelock II locking screws.

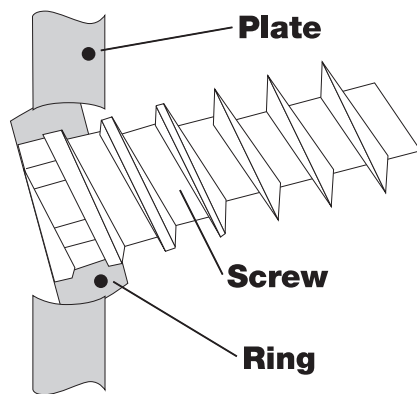

This mechanism permits screws to be adjusted through a continuum of 15° from orthogonal, tracing out a cone of up to 30° in all directions. This capability allows the surgeon to aim the screw at an optimal trajectory, within the 30° cone.

The Numelock II screws have a unique conical core design and thread pattern in the head and tip areas. As the screw is threaded into the mechanism, its conical head part engages with the corresponding threads in the ring, which in turn expands into the plate, securely locking the position of the screw at the chosen angle and direction.

Prior to final locking of the Numelock II screw within the mechanism, the ring is designed to rotate freely. This attribute can be used to pull a bone segment into alignment (see Operative Technique – General Principles, Step Five, for additional information on this feature).



Compatibility

The screw holes in the diaphyseal portion of the plates are neutral and permit incremental adjustment to the plate's position on the bone. These diaphyseal holes are designed to accept Stryker's SPS (ISO standard) screws. All upper extremity Numelock II plates accept 3.5mm standard cortical screws and 4.0mm standard cancellous screws in the diaphyseal holes. All lower extremity Numelock II plates accept 4.5mm standard cortical screws in the diaphyseal holes. The number of diaphyseal holes depends on each given plate's length.

Instrumentation

The Numelock II instrumentation is designed for accuracy and ease of use and precisely engages with all Numelock II implant components. The storage trays conveniently house the Numelock II instrument set and provide storage for unpacked Numelock II screws, including a compartment for miscellaneous unpacked plates or other instruments of choice.

Introduction

Cases and Trays

The complete Numelock II set consists of two individual cases containing the 4.5mm and 6.5mm Numelock II instrumentation, respectively. The bases include a compartment for additional and miscellaneous instruments or unpacked plates. There are also two individual insert trays that can house unpacked 4.5mm or 6.5mm screws respectively. All Numelock II plates and screws are packaged sterile.



Locking Screw Instrumentation

The range of instruments included in each complete Numelock II set consists of Drill Guides and Drill Bits for placement of 4.5mm and 6.5mm Numelock II locking screws; Screw Drivers; Ring Drivers and Holding Spanners. Additionally, each storage base houses a set of Plate Bending Irons and Depth Gauges.

Note:

Both Numelock II screw sizes (4.5mm and 6.5mm) use the same Depth Gauge (Ref. No. JA65) for measuring length.



Locking Screws

The Numelock II screws are available in 4.5mm and 6.5mm diameters. The 4.5mm screws, for upper extremity and distal medial tibia indications, are supplied in lengths from 14mm to 75mm (14mm – 26mm in 2mm increments; 29mm – 38mm in 3mm increments; 42mm – 50mm in 4mm increments; 55mm – 75mm in 5mm increments). The 6.5mm screws, for distal femur and proximal tibia indications are provided in lengths from 27mm to 85mm (27mm – 45mm in 3mm increments; 50mm – 85mm in 5mm increments).



Indications

The physician's education, training and professional judgment must be relied upon to choose the most appropriate device and treatment. Conditions presenting an increased risk of failure include:

- Any active or suspected latent infection or marked local inflammation in or about the affected area.

Implants of the Numelock II System are indicated for fractures in the following areas:



Lateral Distal Humerus Plate



Lateral Distal Femur Plate



Lateral Proximal Tibia Plate



Medial Distal Tibia Plate

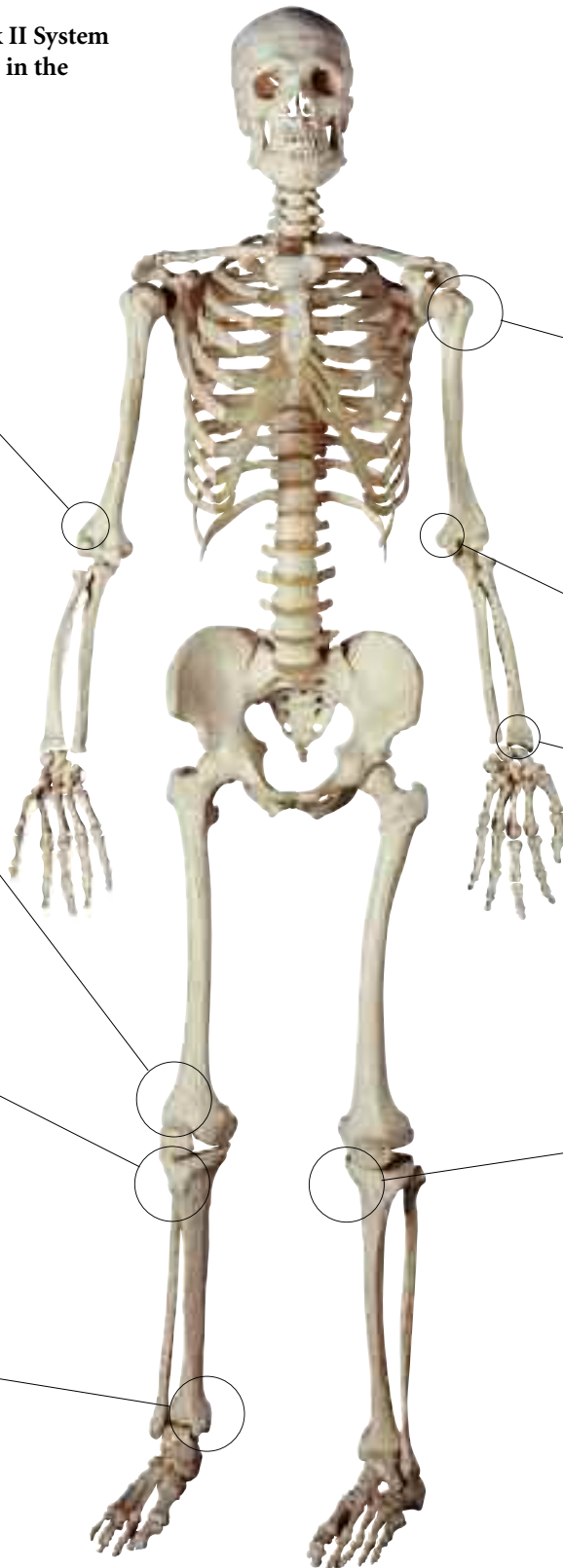

- Compromised vascularity that would inhibit adequate blood supply to the fracture or the operative site.
- Bone stock compromised by disease, infection or prior implantation that cannot provide adequate support and/or fixation of the devices.

- Material sensitivity documented or suspected.
- Obesity. An overweight or obese patient can produce loads on the implant which can lead to failure of the fixation of the device or to failure of the device itself.
- Patients having inadequate tissue coverage over the operative site.
- Implant utilization that would interfere with anatomical structures or physiological performance.
- Any mental or neuromuscular disorder which would create an unacceptable risk of fixation failure or complications in postoperative care.
- Other medical or surgical conditions which would preclude the potential benefit of surgery.

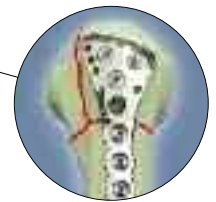

Lateral Proximal Humerus Plate



Volar Distal Radius Plate



Medial Distal Humerus Plate

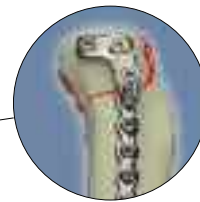

Medial Proximal Tibia Plate

The Numelock II System implants may also be used in revision surgeries of pseudoarthroses, non-unions and mal-unions. Osteotomies and arthrodeses may also be performed using these implants with the applicable operative technique.

Contraindications

Relative Contraindications

Since external fixation devices are often used in emergency situations to treat patients with acute injuries, there are no absolute contraindications for use. The surgeon's education, training and professional judgement must be relied upon to choose the most appropriate device and treatment for each individual patient. Whenever possible, the device chosen should be of a type indicated for the fracture being treated and/or for the procedure being utilized.

Conditions presenting an increased risk of failure include:

- Insufficient quantity or quality of bone which would inhibit appropriate fixation of the device.
- Compromised vascularity that would inhibit adequate blood supply to the fracture or operative site.
- Previous history of infections.
- Any neuromuscular deficit which could interfere with the patient's ability to limit weight bearing.
- Any neuromuscular deficit which places an unusually heavy load on the device during the healing period.
- Malignancy in the fracture area.
- Mental, physical or neurological conditions which may impair the patient's ability to cooperate with the postoperative regimen.
- Patients with a compromised immune system.
- Pre-existing internal fixation that prohibits proper pin placement.

Features and Benefits

Features Benefits

- | | |
|--|---|
| Axially stable, locking fixation in epiphysis/metaphysis | • High stability; protection against primary and secondary losses of reduction; limited plate contact with periostium; reliable purchase in normal and osteoporotic bone. |
| Polyaxial locking mechanism | • Screws positioned according to fracture pattern or to avoid another implant; plate positioned to meet needs of patient anatomy. |
| 30° range of screw insertion angles | • Adjustability in range of screw trajectories over a continuum of positions. |
| Eight plates cover five anatomical regions | • Broad indication coverage with one system. |
| All plates and screws packaged sterile | • Safety, traceability, convenience. |
| Screws with unique thread and conical core design | • Low insertion torque and secure locking; reduced possibility of cross-threading and cold welding. |
| Shaft holes accept SPS ISO screws | • Can be used with existing hospital inventory of SPS ISO standard screws. |
| Ring Driver permits screw and bone segment adjustments | • Distance of bone to plate can be accurately adjusted; bone segments may be pulled towards plate. |
| Anatomically shaped plates | • Limited need for contouring. |
| Numelock screws accept standard hex drivers | • Screws can be removed with standard drivers at end of treatment, in case of plate extraction. |
| 4.5mm and 6.5mm implants and instruments | • Coverage of both upper and lower extremities. |
| Rounded plate ends | • Reduced potential for soft tissue irritation. |
| K-Wire/suture holes in Proximal Humerus Plate | • Well-suited for rotator cuff reattachment. |
| Drill guide constrains screw insertion angle | • Limits screw head protrusion for reduced soft tissue irritation. |
| Numelock II Screw Depth Gauge gives direct value | • No compensation required for Numelock II locking screws. |
| Complete set provided in separately housed 4.5/6.5 kits | • Space saving in operating theater. |

Operative Technique

General Principles

The surgeon must first determine clear identification and classification of the fracture using the suitable imaging methods.

The appropriate anatomical reduction must be established before any definitive fixation is undertaken.

Step One – Plate Contouring and Shaft Screw Placement

- Establish primary stabilization of the fracture site through the use of reduction forceps and/or K-Wire in the appropriate manner. Although the plates are pre-shaped, the diaphyseal portion of the implant may require contouring with the Plate Bending Irons (Ref. No. TRTPS).
- Once the required shape has been fashioned, the plate should be positioned on the bone for optimal stability and ultimate fixation.



- Note that bending in the epiphyseal/metaphyseal part of the plate should be avoided as this may damage the locking mechanisms. Moreover, it is not necessary to contour in this part of the plate because it is already pre-shaped and the underside of the plate in this region need not be in contact with the periosteal surface once the locking screws are engaged.
- The Numelock II Drill Guide (Ref. No. GM25 for 4.5mm Numelock II Plates or GM35 for 6.5mm Numelock II Plates) can be threaded into one of the epiphyseal/metaphyseal locking holes to assist with plate positioning and holding. However, the Numelock II Drill Guide is not for use with diaphyseal screw placement.

- Pre-drill and measure for placement of an SPS Cortical Screw into one of the diaphyseal holes using the appropriate sized Drill Bit, Drill Guide and Measuring Gauge from your SPS set. 3.5mm SPS Cortical Screws (or 4.0mm Cancellous Screws) are used for upper extremity Numelock II Plates and 4.5mm SPS Cortical Screws are used for lower extremity Numelock II Plates.
- The SPS Cortical Screws are self-tapping. Typically, the first screw position corresponds to one of the middle diaphyseal holes (or, if more appropriate, the next hole towards the joint can also be used). It is not recommended that the first diaphyseal screw be placed into the last diaphyseal hole. Avoid using screw hole(s) immediately adjacent to fracture line(s). After insertion, this screw should not be tightened completely to allow for pivotal adjustment of the plate's positioning.
- Once the orientation of the plate has been finalized, place a second screw into a second diaphyseal hole at least one hole space away from the first screw and securely tighten both screws.

Step Two – Pre-drilling for Locking Screw Placement

- Choosing a hole position that is closest to being equidistant from medial to lateral, thread the Drill Guide (Ref. No. GM25 for 4.5mm Numelock II Plates or GM35 for 6.5mm Numelock II Plates) into the locking mechanism of one of the epiphyseal/metaphyseal holes and position it at the desired angle.



- The Drill Guide constrains the drilling angle, ensuring optimal screw head profile to minimize possible soft tissue irritation.
- Using the appropriate diameter Numelock II Drill Bit (Ref. No. 700351 for 4.5mm screws or MCA35195 for 6.5mm screws), create a pilot hole for screw insertion.
- It is important to preplan the angles of inclination for each of the Numelock II epiphyseal/metaphyseal locking screws to optimize the fixation of any fragments while exercising extreme caution to avoid collision of any screws inside the bone and to avoid penetration of joint surfaces. When feasible, to avoid such intersection of the Numelock II screws within the bone, it is desirable to place them at divergent angles to each other.

Operative Technique

General Principles

Step Two continued – Pre-drilling for Locking Screw Placement.

- If hard cortical bone is encountered, use the tip of the Cutting Screwdriver (Ref. No. TASH5 for 4.5mm screws or TASH7 for 6.5mm screws) to incise the near cortex. Additionally, a 3.2mm Drill Bit (Ref. No. 700356) for 4.5mm screws and a 4.5mm Drill Bit (Ref. No. 700354) for 6.5mm screws are supplied and may be used to overdrill the near cortex in case of hard bone.

Note:

The Drill Guides cannot be used for overdrilling.

Step Three – Depth measurement (Fig.1)

- Using the Numelock II Depth Gauge (Ref. No. JA65), measure the depth of the metaphyseal pilot hole directly through the plate. The depth gauge provides the actual length of the screw required.

Note:

This Depth Gauge is not designed to measure the lengths of standard SPS screws. If transport of a bone segment is anticipated (see Step 5) a shorter screw than the length measured for that fragment will usually be required.

Step Four – Locking Screw Placement (Fig.2)

- Using the Cutting Screwdriver (Ref. No. TASH5 for 4.5mm screws or TASH7 for 6.5mm screws), insert the Numelock II locking screw as far as possible without locking the ring mechanism. Prevent rotation of the ring mechanism by engaging the Holding Spanner's (Ref. No. CESH5 for 4.5mm screws or CESH7 for 6.5mm screws) teeth with the corresponding slots in the ring. Repeat Steps Two through Four for all screw positions in the epiphysis/metaphysis. If transport of a bone fragment is anticipated, see Step Five.



Fig.1



Fig.2

Operative Technique

General Principles

Step Five – Final Adjustments / Transport (Fig.3)

- To adjust the position of the bone with respect to the plate or to pull a bone segment closer to the plate, use the Ring Driver (Ref. No. TVESH5 for 4.5mm screws or TVESH7 for 6.5mm screws) with automatic centering. By turning the ring clockwise with the Ring Driver, the bone is moved closer to the plate as required.

Note:

Further displacement of the bone to the plate is no longer possible if more than three Numelock II locking screws have been applied.

Note:

If using this feature to realign two bone segments, the orientation of screw placement must be parallel to the plane of the line of the fracture associated with these two segments.



Fig.3

Step Six – Final Locking (Fig.4)

- When all desired adjustments are complete, lock each Numelock II screw with the screwdriver while holding the ring steady with the Holding Spanner. Firm tightening of the screws ensures stability. After locking, it is no longer possible to rotate the ring without damaging the locking mechanism.

Note:

To guarantee maximum stability, fill all Numelock II holes with a screw of appropriate length.

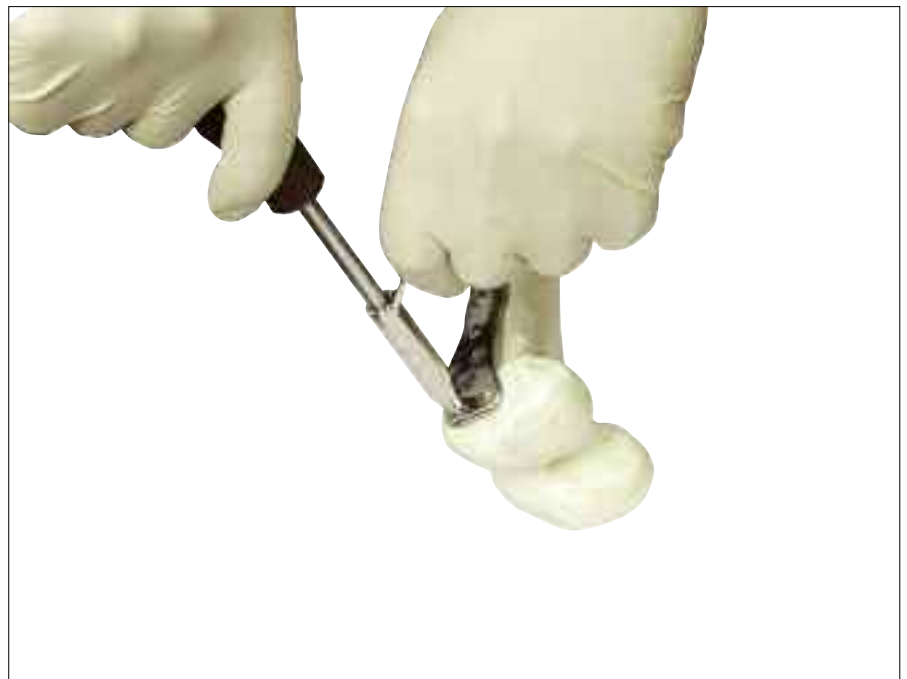

Fig.4

Step Seven – Remaining Diaphyseal Screws

- Pre-drill and measure for placement of remaining SPS Cortical Screws as necessary. Insert screws and securely tighten.

Operative Technique

Indication Procedures

Proximal Humerus

Principal Indications:

- Fractures of the proximal segment of the humerus (2, 3 and 4 part fractures).

Surgical Approach:

- Deltoidpectoral.

Tips and Additional Information:

- The additional small holes in the plate allow for the placement of Kirschner Wires to facilitate fracture reduction and for maintaining the reduction in correct position.
- Posterior sutures can be sewn through these holes to facilitate reattachment of the tuberosities.
- The placement of proximal axially stable (locking) screws enhances the stability of the construct.

Post-Operative Considerations:

- Usage of axially stable locking screws in the plate may permit mobilization of the shoulder joint in the early post-operative phase.



Distal Humerus

Principal Indications:

- Extra-articular supra-condylar fractures.
- Fractures above and within the condyles.
- Epicondylar and lateral column fractures.
- Epitrochlear and medial column fractures.

Surgical Approach:

- The standard approach is made through a posterior medial incision.
- According to the type and location of the fracture, additional approaches may be necessary.

Tips and Additional Information:

- The diaphyseal screws must be positioned before insertion of the epiphyseal/metaphyseal screws to minimize risk of secondary displacement in the frontal plane into varus or valgus deformity.
- The Numelock II plating system permits the use of a single lateral plate for many distal humerus fractures. This is due to the inherent stability of the construct which can make the use of an additional medial plate unnecessary.
- If the fracture affects only the medial structures, fixation with only a medial plate is often sufficient.

Post-Operative Considerations:

- Mobilization is possible in the early post-operative phase.
- The stability provided by the locking screws allows many of these fractures to be stabilized using only a lateral plate, without the need for a medial plate.
- Depending on the fracture and at the surgeon's discretion, a single lateral plate or two plates fixed medially and laterally may be used. The choice and number of plates used needs to be taken into consideration for determining correct post-operative rehabilitation protocol.



Operative Technique

Indication Procedures

Proximal Tibia

Principal Indications:

- Fractures of the tibial condyles
 - Lateral (most frequent).
 - Medial.
 - Bi-condylar.
- Extra-articular metaphyseal fractures.

Surgical Approach:

- The optimal approach is through a lateral or medial incision depending on the zone of the fracture.

Tips and Additional Information:

- Given that affected articulations must be accurately reduced to restore anatomical integrity, the use of additional bone graft (in cases with major crushing) is strongly advised.
- Placement of the plate begins with positioning of the diaphyseal screws and ends with placement of the metaphyseal and epiphyseal screws.
- Adjustments of the metaphyseal screws to compress the plate to the bone (see Step Five of General Principles) are indicated for fractures in the region of the tibial tuberosity.
- A similar adjustment using the epiphyseal screws can be implemented in bicondylar fractures (type V in Schatzker's classification) or fractures involving the tibial eminence.
- In most cases, application of two plates (lateral and medial) should be avoided. The concept of this axially stable system is such that fixation with a single lateral plate is usually sufficient.

Post-Operative Considerations:

- Early mobilization and partial weight-bearing are possible for metaphyseal fractures without cartilaginous complications in the joint.
- In cases with cartilaginous involvement, mobilization without weight-bearing may be possible.
- Usage of a brace may be considered.



Distal Tibia

Principal Indications:

- Extra-articular fractures of the distal tibia.
- Articular tibial (pilon) fractures.

Surgical Approach:

- The optimal approach is through a medial or posterior medial incision.

Tips and Additional Information:

- Contouring of the proximal part of the plate is particularly important to minimize possible irritation of the soft tissues.
- The anterior and distal parts of the plate allow control of certain anterior or posterior bone fragments.
- It is usually not necessary to place more than three axially stable (locking screws). Surgeon discretion is required.

Post-Operative Considerations:

- Early mobilization is encouraged for supramalleolar, extra-articular fractures.
- Usage of a brace may be considered.



Operative Technique

Indication Procedures

Distal Radius

Principal Indications:

- Extra and intra-articular fractures of the distal fourth of the radius.

Surgical Approach:

- The optimal approach is the classic volar entry, going through the pronator quadratus muscle.

Tips and Additional Information:

- The distal epiphyseal locking screws provide stability to the construct and help to minimize occurrence of secondary displacements.
- Severely comminuted fractures may necessitate a supplementary dorsal approach.

Post-Operative Considerations:

- The grip of the screws in the volar plate ensures the stability of the construct and usually eliminates the need for an additional posterior approach and reduction.
- Active range of motion with flexion/extension is encouraged in the immediate post-operative phase, without need for additional immobilization in the majority of cases.



Distal Femur

Principal Indications:

- Supra-condylar extra-articular fractures.
- Fractures above the condyles.
- Intercondylar fractures.

Surgical Approach:

- The lateral approach is optimal, going beneath the vastus lateralis muscle.

Tips and Additional Information:

- Articular structures must be reduced first.
- The plate must be well adapted anatomically by bending if necessary, but only in the proximal part to avoid damage to the distal locking system.
- Diaphyseal screws are inserted first, followed by fixation of the metaphyseal zone and then followed by fixation in the epiphyseal region.
- Frontal (Hoffa type) fractures are reduced using additional, independent anteriorposterior screws which are not in the plate.

Post-Operative Considerations:

- Early mobilization may be considered if all five locking screws are placed in the condylar region.
- Weight-bearing should be postponed in cases with joint involvement with cartilaginous lesions.
- Usage of a brace may be considered.



Clinical Examples

Distal Humerus



Distal Femur



Proximal Tibia



Ordering information – Plates

Stainless Steel, Packaged Sterile

PROXIMAL HUMERUS

Standard Screws Diameter 3.5mm

Locking Screws Diameter 4.5mm



Stainless Steel REF	Length mm	Side	Locking Holes	Shaft Holes
SHHP8TDS *	75	Right	4	4
SHHP8TGS *	75	Left	4	4
SHHP10TDS *	95	Right	4	6
SHHP10TGS *	95	Left	4	6
SHHP12TDS	115	Right	4	8
SHHP12TGS	115	Left	4	8
SHHP14TDS *	135	Right	4	10
SHHP14TGS *	135	Left	4	10

LATERAL DISTAL HUMERUS

Standard Screws Diameter 3.5mm

Locking Screws Diameter 4.5mm



Stainless Steel REF	Length mm	Side	Locking Holes	Shaft Holes
SHBEP7TDS *	85	Right	5	2
SHBEP7TGS *	85	Left	5	2
SHBEP8TDS *	98	Right	5	3
SHBEP8TGS *	98	Left	5	3
SHBEP10TDS	124	Right	5	5
SHBEP10TGS	124	Left	5	5

MEDIAL DISTAL HUMERUS

Standard Screws Diameter 3.5mm

Locking Screws Diameter 4.5mm



Stainless Steel REF	Length mm	Side	Locking Holes	Shaft Holes
SHBIP5TS *	70	Symmetrical	4	1
SHBIP7TS *	100	Symmetrical	4	3
SHBIP9TS	130	Symmetrical	4	5

VOLAR DISTAL RADIUS

Standard Screws Diameter 3.5mm

Locking Screws Diameter 4.5mm



Stainless Steel REF	Length mm	Side	Locking Holes	Shaft Holes
SRBIP7TDS *	57	Right	4	3
SRBIP7TGS *	57	Left	4	3
SRBIP8TDS *	67	Right	4	4
SRBIP8TGS *	67	Left	4	4

* Recommended Item

Ordering information – Plates

Stainless Steel, Packaged Sterile

LATERAL DISTAL FEMUR

Standard Screws Diameter 4.5mm

Locking Screws Diameter 6.5mm



Stainless Steel REF	Length mm	Side	Locking Holes	Shaft Holes
SFBEP10TDS *	124	Right	5	5
SFBEP10TGS *	124	Left	5	5
SFBEP12TDS *	158	Right	5	7
SFBEP12TGS *	158	Left	5	7
SFBEP14TDS *	192	Right	5	9
SFBEP14TGS *	192	Left	5	9
SFBEP16TDS	226	Right	5	11
SFBEP16TGS	226	Left	5	11

LATERAL PROXIMAL TIBIA

Standard Screws Diameter 4.5mm

Locking Screws Diameter 6.5mm



Stainless Steel REF	Length mm	Side	Locking Holes	Shaft Holes
STHEP7TDS *	84	Right	3	4
STHEP7TGS *	84	Left	3	4
STHEP8TDS *	97	Right	3	5
STHEP8TGS *	97	Left	3	5
STHEP9TDS	110	Right	3	6
STHEP9TGS	110	Left	3	6
STHEP10TDS *	123	Right	3	7
STHEP10TGS *	123	Left	3	7

MEDIAL PROXIMAL TIBIA

Standard Screws Diameter 4.5mm

Locking Screws Diameter 6.5mm



Stainless Steel REF	Length mm	Side	Locking Holes	Shaft Holes
STHIP8TDS *	91	Right	3	5
STHIP8TGS *	91	Left	3	5
STHIP10TDS *	117	Right	3	7
STHIP10TGS *	117	Left	3	7
STHIP12TDS *	143	Right	3	9
STHIP12TGS *	143	Left	3	9
STHIP14TDS	169	Right	3	11
STHIP14TGS	169	Left	3	11

MEDIAL DISTAL TIBIA

Standard Screws Diameter 4.5mm

Locking Screws Diameter 4.5mm



Stainless Steel REF	Length mm	Side	Locking Holes	Shaft Holes
STBIP9TDS *	81	Right	6	3
STBIP9TGS *	81	Left	6	3
STBIP11TDS *	107	Right	6	5
STBIP11TGS *	107	Left	6	5
STBIP13TDS *	133	Right	6	7
STBIP13TGS *	133	Left	6	7
STBIP15TDS	159	Right	6	9
STBIP15TGS	159	Left	6	9

* Recommended Item

Ordering information – Locking Screws

4.5MM LOCKING SCREWS STAINLESS STEEL, PACKAGED STERILE



StSt REF	Length mm
S5SH14S *	14
S5SH16S *	16
S5SH18S *	18
S5SH20S *	20
S5SH22S *	22
S5SH24S *	24
S5SH26S *	26
S5SH29S *	29
S5SH32S *	32
S5SH35S *	35
S5SH38S *	38
S5SH42S *	42
S5SH46S *	46
S5SH50S *	50
S5SH55S *	55
S5SH60S *	60
S5SH65S *	65
S5SH70S *	70
S5SH75S *	75

















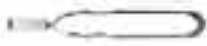

6.5MM LOCKING SCREWS STAINLESS STEEL, PACKAGED STERILE



StSt REF	Length mm
S7SH27S *	27
S7SH30S *	30
S7SH33S *	33
S7SH36S *	36
S7SH39S *	39
S7SH42S *	42
S7SH45S *	45
S7SH50S *	50
S7SH55S *	55
S7SH60S *	60
S7SH65S *	65
S7SH70S *	70
S7SH75S *	75
S7SH80S *	80
S7SH85S *	85



* Recommended Item

Ordering information – Instruments

	REF	Description
4.5mm Instrumentation		
	TRTPS *	Plate Bending Iron (two required)
	GM25 *	Drill Guide
	700351 *	2.5mm Drill Bit
	700356 *	3.2mm Drill Bit
	JA65 *	Depth Gauge
	TASH5 *	Cutting Screwdriver
	TVESH5 *	Ring Driver
	CESH5 *	Holding Spanner
	900106 *	Screw Forceps
6.5mm Instrumentation		
	TRTPS *	Plate Bending Iron (two required)
	GM35 *	Drill Guide
	MCA35195 *	3.5mm Drill Bit
	700354 *	4.5mm Drill Bit
	JA65 *	Depth Gauge
	TASH7 *	Cutting Screwdriver
	TVESH7 *	Ring Driver
	CESH7 *	Holding Spanner
	900106 *	Screw Forceps

* Recommended Item

Ordering information – Cases and Trays

	REF	Description
	BALOCK5	4.5mm Instrument Storage Base
	BALOCK7	6.5mm Instrument Storage Base
	INLOCK5	4.5mm Locking Screw Storage Tray
	INLOCK7	6.5mm Locking Screw Storage Tray
	COLOCK	Lid (Fits 4.5mm and 6.5mm Storage Bases)
	TALOCK	Silicon Mat (Fits inside miscellaneous compartments of 4.5mm and 6.5mm Storage Bases)

Notes

Joint Replacements

Trauma, Extremities & Deformities

Craniomaxillofacial

Spine

Biologics

Surgical Products

Neuro & ENT

Interventional Spine

Navigation

Endoscopy

Communications

Imaging

Patient Care & Handling Equipment

EMS Equipment

Stryker Trauma AG
Bohnackerweg 1
CH-2545 Selzach
Switzerland

www.osteosynthesis.stryker.com

This document is intended solely for the use of healthcare professionals. A surgeon must always rely on his or her own professional clinical judgment when deciding whether to use a particular product when treating a particular patient. Stryker does not dispense medical advice and recommends that surgeons be trained in the use of any particular product before using it in surgery. The information presented in this brochure is intended to demonstrate a Stryker product. Always refer to the package insert, product label and/or user instructions including the instructions for Cleaning and Sterilization (if applicable) before using any Stryker products. Products may not be available in all markets. Product availability is subject to the regulatory or medical practices that govern individual markets. Please contact your Stryker representative if you have questions about the availability of Stryker products in your area.

Stryker Corporation or its divisions or other corporate affiliated entities own, use or have applied for the following trademarks or service marks: Stryker, Numelock II.

All other trademarks are trademarks of their respective owners or holders.
The products listed above are CE marked.

Literature Number: 982195
LOT B1309

Copyright ©2009 Stryker

